

- HIGH-LEVEL AND BINARY-LEVEL SPECIFICATIONS
- REPRESENTATION OF DATA ELEMENTS BY BINARY VARIABLES; STANDARD CODES FOR POSITIVE INTEGERS AND CHARACTERS
- REPRESENTATION BY SWITCHING FUNCTIONS AND SWITCHING EXPRESSIONS
- NOT, AND, OR, NOR, XOR, and XNOR SWITCHING FUNCTIONS
- TRANSFORMATION OF SWITCHING EXPRESSIONS USING SWITCHING ALGEBRA
- USE OF VARIOUS SPECIFICATION METHODS
- USE OF THE μ VHDL DESCRIPTION LANGUAGE

COMBINATIONAL SYSTEM

$$z(t) = F(x(t)) \quad \text{or} \quad z = F(x)$$

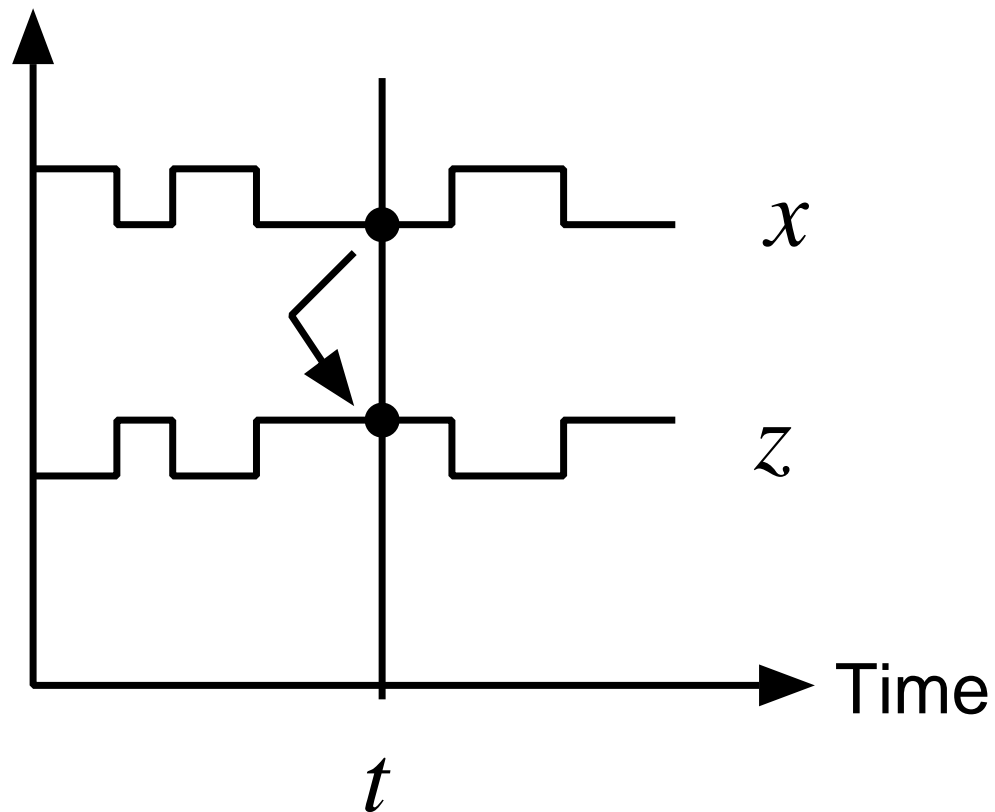

Figure 2.1: Combinational system.

$$z_b = F_b(x_b)$$

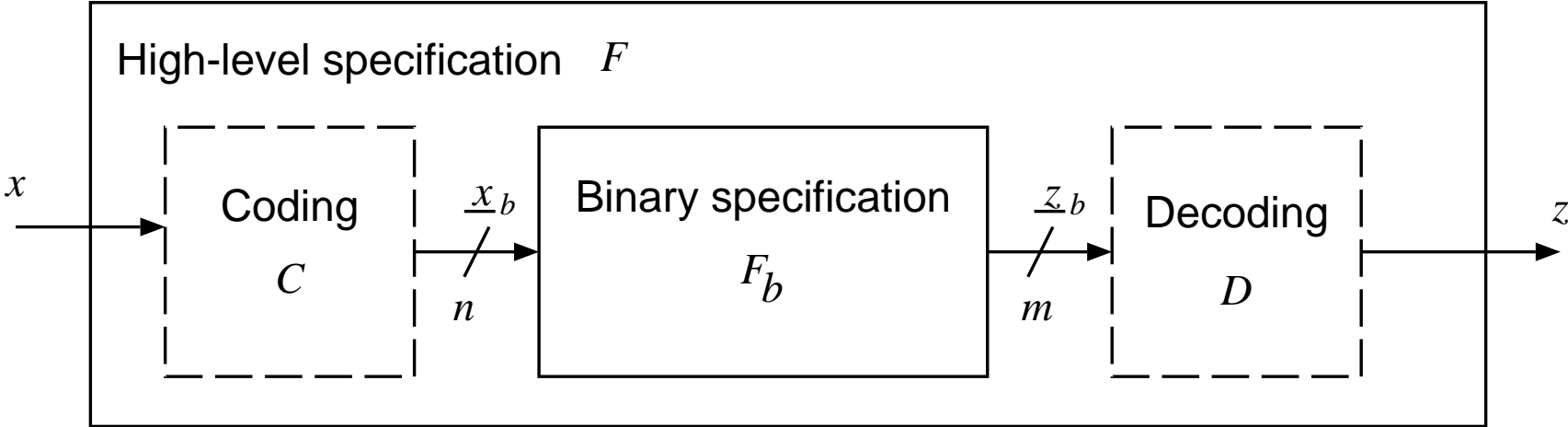

Figure 2.2: High-level and binary-level specification.

Example 2.1:

Input: $x \in \{0, 1, 2, 3, 4, 5, 6, 7, 8, 9\}$

Output: $z \in \{0, 1, 2\}$

Function: F is described by the following table

x	0	1	2	3	4	5	6	7	8	9
$z = F(x)$	0	1	2	0	1	2	0	1	2	0

or by the arithmetic expression

$$z = x \bmod 3,$$

x	0	1	2	3	4	5	6	7	8	9
$\underline{x}_b = C(x)$	0000	0001	0010	0011	0100	0101	0110	0111	1000	1001

\underline{z}_b	00	01	10
$z = D(\underline{z}_b)$	0	1	2

Input: $\underline{x}_b = (x_3, x_2, x_1, x_0), x_i \in \{0, 1\}$

Output: $\underline{z}_b = (z_1, z_0), z_i \in \{0, 1\}$

Function: F_b is described by the following table

\underline{x}_b	0000	0001	0010	0011	0100	0101	0110	0111	1000	1001
$\underline{z}_b = F_b(\underline{x}_b)$	00	01	10	00	01	10	00	01	10	00

- SET OF VALUES FOR THE INPUT, *input set*;
- SET OF VALUES FOR THE OUTPUT, *output set*; and
- SPECIFICATION OF THE *input-output function*.

$$\{UP, DOWN, LEFT, RIGHT, FIRE\}$$

$$\{x \mid (5 \leq x \leq 10^4) \text{ and } (x \bmod 3 = 0)\}$$

Examples of vectors

Vector type		Example
Digit	$\underline{x} = (x_{n-1}, x_{n-2}, \dots, x_0)$ $x_i \in \{0, 1, 2, \dots, 9\}$	$\underline{x} = (7, 0, 6, 3)$
Character	$\underline{c} = (c_{n-1}, c_{n-2}, \dots, c_0)$ $c_i \in \{ , A, B, \dots, Z\}$	$\underline{c} = (B, O, O, K)$
Set	$\underline{s} = (s_{n-1}, s_{n-2}, \dots, s_0)$ $s_i \in \{\text{red, blue, white}\}$	$\underline{s} = (\text{red, blue, blue})$
Bit	$\underline{y} = (y_{n-1}, y_{n-2}, \dots, y_0)$ $y_i \in \{0, 1\}$	$\underline{y} = (1, 1, 0, 1, 0, 0)$ $\underline{y} = 110100$

1. TABLE

x	z
A	65
B	66
C	67
D	68
E	69

2. ARITHMETIC EXPRESSION

$$z = 3x + 2y - 2$$

3. CONDITIONAL EXPRESSION

$$z = \begin{cases} a + b & \mathbf{if} & c > d \\ a - b & \mathbf{if} & c = d \\ 0 & \mathbf{if} & c < d \end{cases}$$

4. LOGICAL EXPRESSION

$$z = (\text{SWITCH1} = \text{CLOSED}) \text{ and } (\text{SWITCH2} = \text{OPEN}) \\ \text{or } (\text{SWITCH3} = \text{CLOSED})$$

5. COMPOSITION OF SIMPLER FUNCTIONS

$$\text{max}(v, w, x, y) = \text{GREATER}(v, \text{GREATER}(w, \text{GREATER}(x, y)))$$

in which

$$\text{GREATER}(a, b) = \begin{cases} a & \text{if } a > b \\ b & \text{otherwise} \end{cases}$$

Example 2.2

Inputs: $\underline{x} = (x_3, x_2, x_1, x_0),$
 $x_i \in \{A, B, \dots, Z, a, b, \dots, z\}$
 $y \in \{A, B, \dots, Z, a, b, \dots, z\}$
 $k \in \{0, 1, 2, 3\}$

Outputs: $\underline{z} = (z_3, z_2, z_1, z_0),$
 $z_i \in \{A, B, \dots, Z, a, b, \dots, z\}$

Function: $z_j = \begin{cases} x_j & \text{if } j \neq k \\ y & \text{if } j = k \end{cases}$

Input: $\underline{x} = (C, A, S, E)$, $y = R$, $k = 1$

Output: $\underline{z} = (C, A, R, E)$

{Al, Bert, Dave, Jerry, Len}

	Fixed-length		Variable-length
	Code 1	Code 2	Code 3
Al	000	0110	01
Bert	010	0101	001
Dave	100	0011	0001
Jerry	110	1001	00001
Len	111	1111	000001

ALPHANUMERIC CODES

Character	Codes	
	ASCII	EBCDIC
A	100 0001	1100 0001
B	100 0010	1100 0010
C	100 0011	1100 0011
⋮	⋮	⋮
Y	101 1001	1110 1000
Z	101 1010	1110 1001
0	011 0000	1111 0000
1	011 0001	1111 0001
2	011 0010	1111 0010
⋮	⋮	⋮
8	011 1000	1111 1000
9	011 1001	1111 1001
blank	010 0000	0100 0000
.	010 1110	0100 1011
(010 1000	0100 1101
+	010 1011	0100 1110
⋮	⋮	⋮

A blank C A B .
 01000001 00100000 01000011 01000001 01000010 00101110

REPRESENTATION OF POSITIVE INTEGERS

Level 1: INTEGER \iff *DIGIT-VECTOR*

Level 2: DIGIT \iff *BIT-VECTOR*

Level 1: Integer (Digit-vector)	5			6			3		0			
Level 2: Bit-vector	1	0	1	1	1	0	0	1	1	0	0	0

REPRESENTATION BY DIGIT-VECTOR

$$\underline{x} = (x_{n-1}, x_{n-2}, \dots, x_1, x_0)$$

$$x = \sum_{i=0}^{n-1} x_i r^i$$

DIGIT x_i in $\{0, 1, \dots, r - 1\}$, r – THE RADIX

$$\underline{x} = (1, 0, 0, 1, 0, 1)$$

\iff

$$1 \times 2^5 + 0 \times 2^4 + 0 \times 2^3 + 1 \times 2^2 + 0 \times 2^1 + 1 \times 2^0 = (37)_{10}$$

SET OF REPRESENTABLE VALUES

$$0 \leq x \leq r^n - 1$$

EXAMPLE OF BINARY CODES

Digit Value (Symbol)	Binary	Quaternary	Octal	Hexadecimal
	$k = 1$	$k = 2$	$k = 3$	$k = 4$
	d_0	d_1d_0	$d_2d_1d_0$	$d_3d_2d_1d_0$
0	0	00	000	0000
1	1	01	001	0001
2		10	010	0010
3		11	011	0011
4			100	0100
5			101	0101
6			110	0110
7			111	0111
8				1000
9				1001
10 (A)				1010
11 (B)				1011
12 (C)				1100
13 (D)				1101
14 (E)				1110
15 (F)				1111

BINARY-CODE REPRESENTATION OF A DIGIT-VECTOR

5			6			3			0		
1	0	1	1	1	0	0	1	1	0	0	0

4-bit GRAY CODE

Digit	Gray code
0	0000
1	0001
2	0011
3	0010
4	0110
5	0111
6	0101
7	0100
8	1100
9	1101
10	1111
11	1110
12	1010
13	1011
14	1001
15	1000

GRAY CODE BIT-VECTOR REPRESENTATION OF A DIGIT-VECTOR

9				8				7				6			
1	1	0	1	1	1	0	0	0	1	0	0	0	1	0	1

CODES FOR DECIMAL DIGITS

Digit Value	BCD			
	8421	2421	Excess-3	2-Out-of-5
0	0000	0000	0011	00011
1	0001	0001	0100	11000
2	0010	0010	0101	10100
3	0011	0011	0110	01100
4	0100	0100	0111	10010
5	0101	1011	1000	01010
6	0110	1100	1001	00110
7	0111	1101	1010	10001
8	1000	1110	1011	01001
9	1001	1111	1100	00101

BINARY-LEVEL SPECIFICATION OF C - SYSTEMS

SWITCHING FUNCTIONS



Figure 2.7: a) BINARY COMBINATIONAL SYSTEM; b) A SWITCHING FUNCTION FOR $n = 3$

TABULAR REPRESENTATION OF SWITCHING FUNCTIONS

<i>n</i> -tuple notation		Simplified notation	
$x_2x_1x_0$	$f(x_2, x_1, x_0)$	j	$f(j)$
0 0 0	0	0	0
0 0 1	0	1	0
0 1 0	1	2	1
0 1 1	1	3	1
1 0 0	0	4	0
1 0 1	0	5	0
1 1 0	1	6	1
1 1 1	1	7	1

x_4x_3	$x_2x_1x_0$							
	000	001	010	011	100	101	110	111
00	0	0	1	1	0	1	1	1
01	0	1	1	1	1	0	1	1
10	1	1	0	1	1	0	1	1
11	0	1	0	1	1	0	1	0

f

IMPORTANT SWITCHING FUNCTIONS

Table 2.4: SWITCHING FUNCTIONS OF ONE VARIABLE

x	f_0 0-CONSTANT (always 0)	f_1 IDENTITY (equal to x)	f_2 COMPLEMENT (NOT)	f_3 1-CONSTANT (always 1)
0	0	0	1	1
1	0	1	0	1

Table 2.5: SWITCHING FUNCTIONS OF TWO VARIABLES

Function	x_1x_0				
	00	01	10	11	
f_0	0	0	0	0	
f_1	0	0	0	1	AND
f_2	0	0	1	0	
f_3	0	0	1	1	
f_4	0	1	0	0	
f_5	0	1	0	1	
f_6	0	1	1	0	EXCLUSIVE-OR (XOR)
f_7	0	1	1	1	OR
f_8	1	0	0	0	NOR
f_9	1	0	0	1	EQUIVALENCE (EQU)
f_{10}	1	0	1	0	
f_{11}	1	0	1	1	
f_{12}	1	1	0	0	
f_{13}	1	1	0	1	
f_{14}	1	1	1	0	NAND
f_{15}	1	1	1	1	

INCOMPLETE SWITCHING FUNCTIONS

x	y	z	f
0	0	0	0
0	0	1	1
0	1	0	0
0	1	1	—
1	0	0	1
1	0	1	0
1	1	0	—
1	1	1	1

OR

[*one-set*(1,4,7), *zero-set*(0,2,5)]

[*one-set*(1,4,7), *dc-set*(3,6)]

[*zero-set*(0,2,5), *dc-set*(3,6)]

COMPOSITION OF SWITCHING FUNCTIONS

$$\text{AND}(x_3, x_2, x_1, x_0) = \text{AND}(\text{AND}(x_3, x_2), \text{AND}(x_1, x_0))$$

$$\text{XOR}(x_1, x_0) = \text{OR}(\text{AND}(\text{NOT}(x_0), x_1), \text{AND}(x_0, \text{NOT}(x_1)))$$

$$\begin{aligned} \text{MAJ}(x_3, x_2, x_1, x_0) = \text{OR}(\text{AND}(x_3, x_2, x_1), \text{AND}(x_3, x_2, x_0), \\ \text{AND}(x_3, x_1, x_0), \text{AND}(x_2, x_1, x_0)) \end{aligned}$$

SWITCHING EXPRESSIONS

1. Symbols 0 and 1 are SEs.
2. A symbol representing a binary variable is a SE.
3. If A and B are SEs, then
 - $(A)'$ is a SE. This is referred to as “ A complement.” Sometimes we use \overline{A} to denote complementation.
 - $(A) + (B)$ is a SE. This is referred to as “ A OR B ”; it is also called “ A plus B ” or “sum” due to the similarity with the corresponding arithmetic symbol.
 - $(A) \cdot (B)$ is a SE. This is referred to as “ A AND B ”; it is also called “ A times B ” or “product” due to the similarity with the corresponding arithmetic symbol.

PRECEDENCE RULES: ' PRECEDES · WHICH PRECEDES +

WELL-FORMED SWITCHING EXPRESSIONS ARE:

$$x_0 \quad x_1 + x_2 x_3' \quad 1 + 0(x + y)$$

WHEREAS $(x_1 + 'x_2 +)x_3$ AND “THIS IS A SWITCHING EXPRESSION” ARE NOT.

- *Switching algebra:*

two elements 0 and 1

operations +, ·, and ' (complement)

+	0	1
0	0	1
1	1	1

·	0	1
0	0	0
1	0	1

'	
0	1
1	0

$$E(x_2, x_1, x_0) = x_2 + x_2'x_1 + x_1x_0'$$

The value of E for assignment $(1, 0, 1)$ is

$$E(1, 0, 1) = 1 + 1' \cdot 0 + 0 \cdot 1' = 1 + 0 + 0 = 1$$

REPRESENTING SFs BY SWITCHING EXPRESSIONS

$E(x_2, x_1, x_0) = x_2 + x_2'x_1 + x_1x_0'$ represents f :

$x_2x_1x_0$	f
000	0
001	0
010	1
011	1
100	1
101	1
110	1
111	1

	2 variables	n variables
AND	x_1x_0	$x_{n-1}x_{n-2}\dots x_0$
OR	$x_1 + x_0$	$x_{n-1} + x_{n-2} + \dots + x_0$
XOR	$x_1x_0' + x_1'x_0 = x_1 \oplus x_0$	
EQUIV	$x_1'x_0' + x_1x_0$	
NAND	$(x_1x_0)' = x_1' + x_0'$	$(x_{n-1}x_{n-2}\dots x_0)' = x_{n-1}' + x_{n-2}' + \dots + x_0'$
NOR	$(x_1 + x_0)' = x_1'x_0'$	$(x_{n-1} + x_{n-2} + \dots + x_0)' = x_{n-1}'x_{n-2}'\dots x_0'$

Gate type	Symbol	Switching expression
NOT		$z = x'$
AND		$z = x_1 x_0$
OR		$z = x_1 + x_0$
NAND		$z = (x_1 x_0)'$
NOR		$z = (x_1 + x_0)'$
XOR		$z = x_1 x_0' + x_1' x_0$ $= x_1 \oplus x_0$
XNOR		$z = x_1' x_0' + x_1 x_0$

Figure 2.8: Gate symbols

Gate type	Symbol	Switching expression
AND		$z = x_{n-1} x_{n-2} \dots x_0$
OR		$z = x_{n-1} + x_{n-2} \dots + x_0$

Figure 2.9: n -input AND and OR GATE SYMBOLS

EQUIVALENT SWITCHING EXPRESSIONS

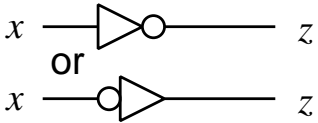
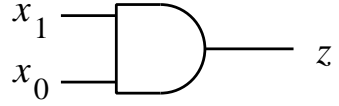
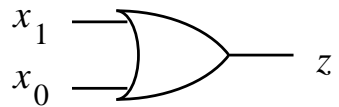
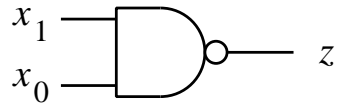
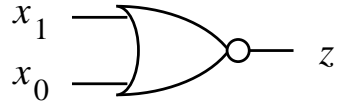
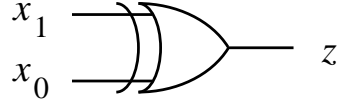
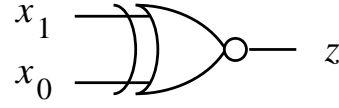
W and Z SWITCHING EXPRESSIONS ARE EQUIVALENT

$$W = x_1x_0 + x'_1$$

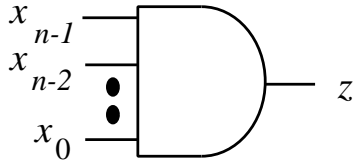
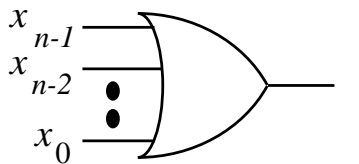
$$Z = x'_1 + x_0$$

CORRESPONDING SWITCHING FUNCTIONS ARE

x_1x_0	W	Z
00	1	1
01	1	1
10	0	0
11	1	1

EQUIVALENCE CLASSES

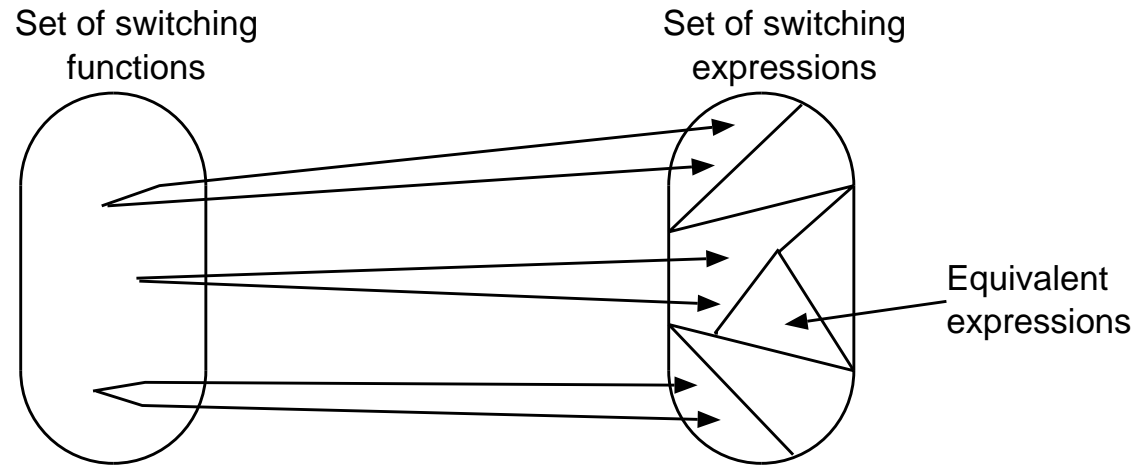

Figure 2.10: CORRESPONDENCE AMONG SFs AND SEs

- MAIN IDENTITIES OF BOOLEAN ALGEBRA

1.	$a + b = b + a$	$ab = ba$	Commutativity
2.	$a + (bc) = (a + b)(a + c)$	$a(b + c) = (ab) + (ac)$	Distributivity
3.	$a + (b + c) = (a + b) + c$ $= a + b + c$	$a(bc) = (ab)c$ $= abc$	Associativity
4.	$a + a = a$	$aa = a$	Idempotency
5.	$a + a' = 1$	$aa' = 0$	Complement
6.	$1 + a = 1$	$0a = 0$	
7.	$0 + a = a$	$1a = a$	Identity
8.	$(a')' = a$		Involution
9.	$a + ab = a$	$a(a + b) = a$	Absorption
10.	$a + a'b = a + b$	$a(a' + b) = ab$	Simplification
11.	$(a + b)' = a'b'$	$(ab)' = a' + b'$	DeMorgan's Law

EXAMPLE

SHOW THAT E_1 AND E_2 ARE EQUIVALENT:

$$E_1(x_2, x_1, x_0) = x_2x_1 + x_2x_1' + x_2x_0$$

$$E_2(x_2, x_1, x_0) = x_2$$

$$\begin{aligned}
 x_2x_1 + x_2x_1' + x_2x_0 &= x_2(x_1 + x_1') + x_2x_0 && \text{using } ab + ac = a(b + c) \\
 &= x_2 \cdot 1 + x_2x_0 && \text{using } a + a' = 1 \\
 &= x_2(1 + x_0) && \text{using } ab + ac = a(b + c) \\
 &= x_2 \cdot 1 && \text{using } 1 + a = 1 \\
 &= x_2 && \text{using } a \cdot 1 = a
 \end{aligned}$$

SUM OF PRODUCTS AND SUM OF MINTERMS

LITERALS	x, y, z', x'
PRODUCT TERMS	$x_0, x_2x_1, x_3x_1x'_0$
SUM OF PRODUCTS (SP)	$x'_2 + x_3x'_1 + x'_3x'_1x_0$

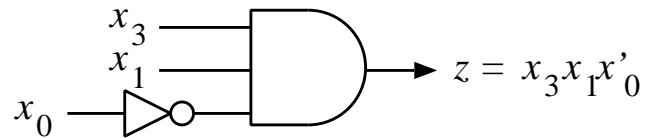

(a)

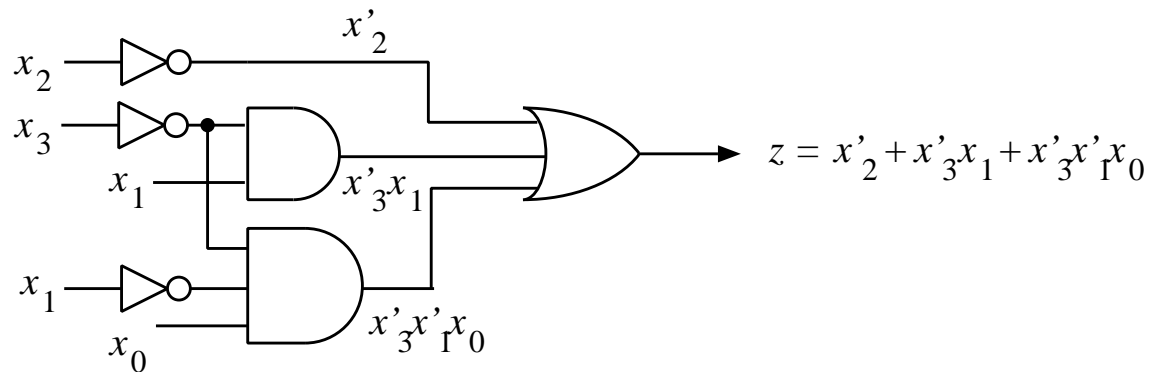

(b)

Figure 2.11: SUM OF PRODUCTS AND AND-OR GATE NETWORK: a) PRODUCT TERM. b) SUM OF PRODUCTS.

MINTERM NOTATION

$$x_i \longleftrightarrow 1; \quad x'_i \longleftrightarrow 0$$

MINTERM m_j , j INTEGER

EXAMPLE: MINTERM $x_3x'_2x'_1x_0$ DENOTED m_9
BECAUSE $1001 = 9$

$$m_j(\underline{a}) = \begin{cases} 1 & \text{if } a = j \\ 0 & \text{otherwise} \end{cases}$$

$$a = \sum_{i=0}^{n-1} a_i 2^i$$

EXAMPLE: $m_{11} = x_3x'_2x_1x_0$

– HAS VALUE 1 ONLY FOR $\underline{a} = (1, 0, 1, 1)$

MINTERM FUNCTIONS

$x_2x_1x_0$	m_0 $x'_2x'_1x'_0$	m_1 $x'_2x'_1x_0$	m_2 $x'_2x_1x'_0$	m_3 $x'_2x_1x_0$	m_4 $x_2x'_1x'_0$	m_5 $x_2x'_1x_0$	m_6 $x_2x_1x'_0$	m_7 $x_2x_1x_0$
000	1	0	0	0	0	0	0	0
001	0	1	0	0	0	0	0	0
010	0	0	1	0	0	0	0	0
011	0	0	0	1	0	0	0	0
100	0	0	0	0	1	0	0	0
101	0	0	0	0	0	1	0	0
110	0	0	0	0	0	0	1	0
111	0	0	0	0	0	0	0	1

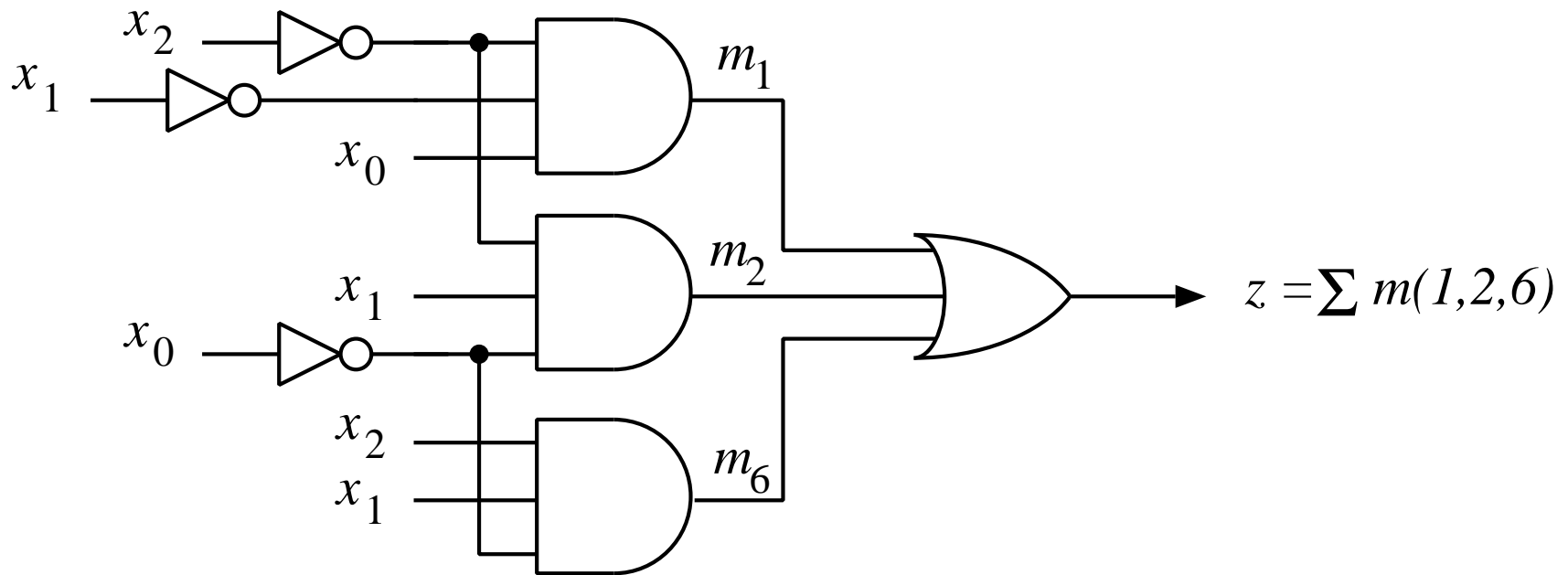

Figure 2.12: GATE NETWORK CORRESPONDING TO $E(x_2, x_1, x_0) = \sum m(1, 2, 6)$.

Example 2.12: TABLE \rightarrow SUM OF MINTERMS

j	x_2	x_1	x_0	f
0	0	0	0	0
1	0	0	1	0
2	0	1	0	1
3	0	1	1	1
4	1	0	0	0
5	1	0	1	1
6	1	1	0	0
7	1	1	1	0

$$E = \Sigma m(2, 3, 5) = x_2'x_1x_0' + x_2'x_1x_0 + x_2x_1'x_0$$

PRODUCT OF SUMS AND PRODUCT OF MAXTERMS

SUM TERMS $x_0, x_2 + x_1, x_3 + x_1 + x'_0$
 PRODUCT OF SUMS $(x'_2 + x_3 + x'_1)(x'_3 + x_1)x_0$

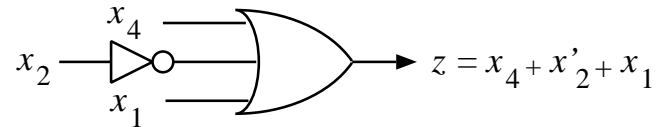

(a)

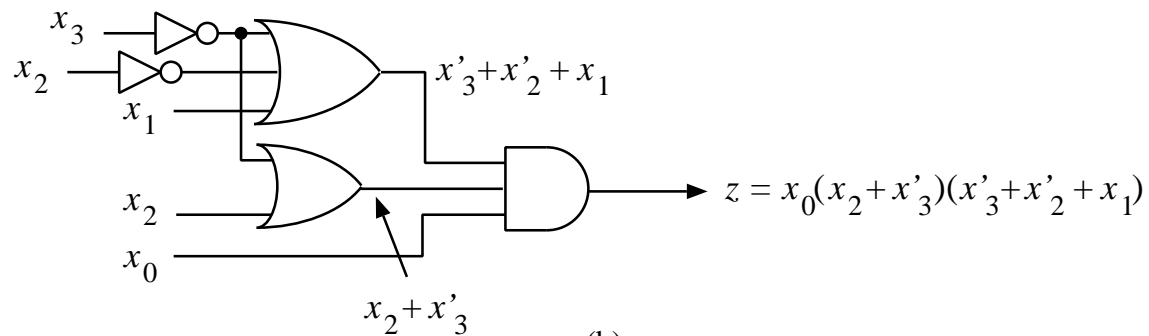

(b)

Figure 2.13: PRODUCT OF SUMS AND OR-AND GATE NETWORK. a) SUM TERM. b) PRODUCT OF SUMS.

MAXTERM NOTATION

$$x_i \longleftrightarrow 0; \quad x'_i \longleftrightarrow 1$$

MAXTERM M_j , j INTEGER

EXAMPLE: MAXTERM $x_3 + x'_2 + x_1 + x'_0$ DENOTED M_5
BECAUSE $0101 = 5$

$$M_j(\underline{a}) = \begin{cases} 0 & \text{if } a = j \\ 1 & \text{otherwise} \end{cases}$$

EXAMPLE: $M_5 = x_3 + x'_2 + x_1 + x'_0$
– HAS VALUE 0 ONLY FOR ASSIGNMENT 0101

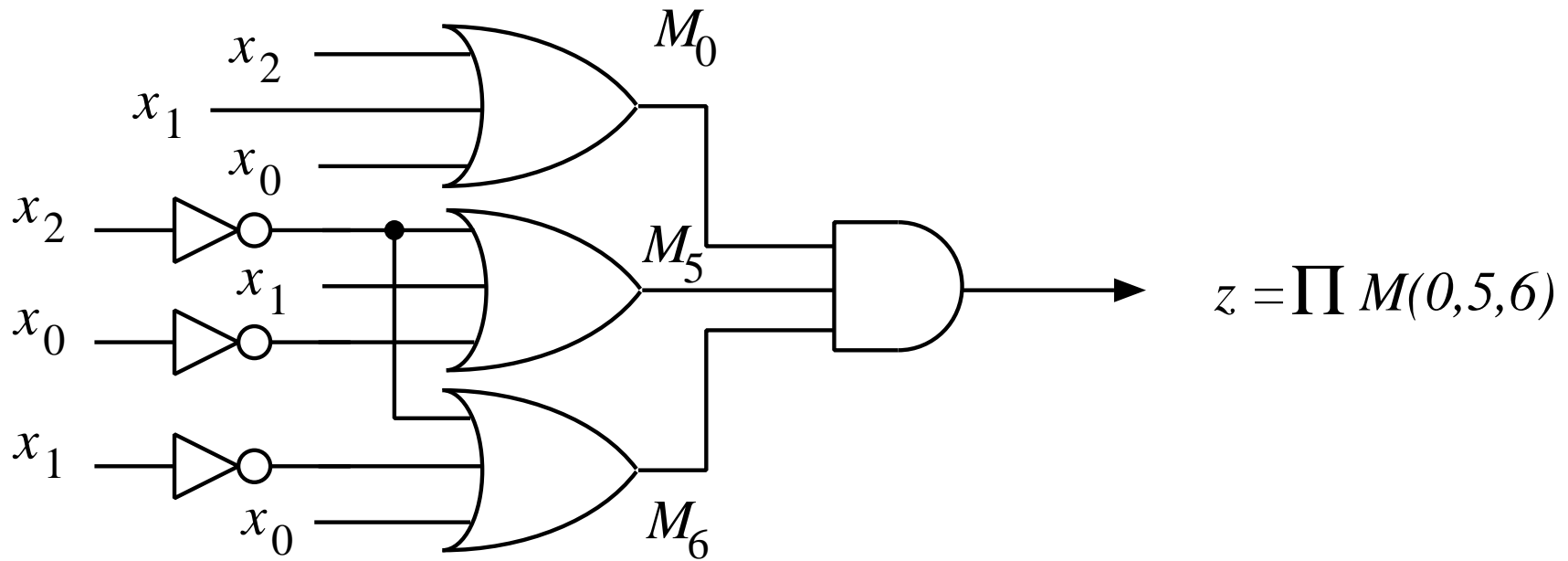

Figure 2.14: GATE NETWORK CORRESPONDING TO $E(x_2, x_1, x_0) = \prod M(0, 5, 6)$.

Example 2.15: TABLE \rightarrow PRODUCT OF SUMS

j	$x_2x_1x_0$	f
0	000	0
1	001	1
2	010	1
3	011	0
4	100	0
5	101	0
6	110	1
7	111	0

$$\begin{aligned}
 E(x_2, x_1, x_0) &= \prod M(0, 3, 4, 5, 7) \\
 &= (x_2 + x_1 + x_0)(x_2 + x'_1 + x'_0)(x'_2 + x_1 + x_0) \\
 &\quad (x'_2 + x_1 + x'_0)(x'_2 + x'_1 + x'_0)
 \end{aligned}$$

CONVERSION AMONG CANONICAL FORMS

SUM OF MINTERMS \longleftrightarrow *one-set*

PRODUCT OF MAXTERMS \longleftrightarrow *zero-set*

\Rightarrow CONVERSION STRAIGHTFORWARD

$$\Sigma m(\{j \mid f(j) = 1\}) = \Pi M(\{j \mid f(j) = 0\})$$

EXAMPLE:

m-NOTATION:

$$f(x, y, z) = \Sigma m(0, 4, 7)$$

M-NOTATION:

$$f(x, y, z) = \Pi M(1, 2, 3, 5, 6)$$

EXAMPLE 2.19: RADIX-4 COMPARATOR

INPUTS: $x, y \in \{0, 1, 2, 3\}$

OUTPUT: $z \in \{G, E, S\}$

FUNCTION: $z = \begin{cases} G & \text{if } x > y \\ E & \text{if } x = y \\ S & \text{if } x < y \end{cases}$

		y			
		0	1	2	3
x	0	E	S	S	S
	1	G	E	S	S
	2	G	G	E	S
	3	G	G	G	E

z

Example 2.19 (cont.)

CODING:

$$x = 2x_1 + x_0 \quad \text{and} \quad y = 2y_1 + y_0$$

z	$z_2z_1z_0$
G	100
E	010
S	001

BINARY SPECIFICATION:

$$z_2 = \begin{cases} 1 & \text{if } x_1 > y_1 \text{ or } (x_1 = y_1 \text{ and } x_0 > y_0) \\ 0 & \text{otherwise} \end{cases}$$

$$z_1 = \begin{cases} 1 & \text{if } x_1 = y_1 \text{ and } x_0 = y_0 \\ 0 & \text{otherwise} \end{cases}$$

$$z_0 = \begin{cases} 1 & \text{if } x_1 < y_1 \text{ or } (x_1 = y_1 \text{ and } x_0 < y_0) \\ 0 & \text{otherwise} \end{cases}$$

x_1x_0	y_1y_0			
	00	01	10	11
00	010	001	001	001
01	100	010	001	001
10	100	100	010	001
11	100	100	100	010

$z_2z_1z_0$

SWITCHING EXPRESSIONS:

$$z_2(x_1, x_0, y_1, y_0) = \sum m(4, 8, 9, 12, 13, 14)$$

$$z_1(x_1, x_0, y_1, y_0) = \sum m(0, 5, 10, 15)$$

$$z_0(x_1, x_0, y_1, y_0) = \sum m(1, 2, 3, 6, 7, 11)$$